



WAREWASHING
UNDERCOUNTER DISHWASHERS

FP | FX





BETTER OR BEST – IT'S YOUR CHOICE!



PROFI-LINE

The **PROFI**-line – everything a professional operator needs. The successful product series from HOBART can be found working wherever the highest standards of cleanliness are required. It combines an efficient rinsing technique with ultimate user-friendliness and low operating costs. Numerous equipment options make **PROFI**-line a perfectly suited warewashing solution to suit any operation.

PREMAX-LINE

The **PREMAX**-line are the perfect models for operators that need a higher level of proficiency. Because **PREMAX** sets standards in all areas: minimal operating costs and impressive user-friendliness, combined with maximum performance. The **PREMAX**-line is the most economical and innovative line of dishwashers on the market. In addition to the features of **PROFI** models, **PREMAX** wins over users with its unique product characteristics and is the ideal partner for the highest standards in a perfect warewashing operation.

PREMAX-LINE EXCLUSIVE

The most exclusive **PREMAX** features are labeled with this writing and a gold background.

WE OFFER YOU THE PERFECT SOLUTION

Are you looking for a dishwasher with perfect long-lasting wash results? Then HOBART is the right choice for you.

However, for us that is just the basic requirement of a dishwasher. In order to make the whole washing process even more convenient and pleasant for you the models from the **PROFI-** and **PREMAX-**line provide a variety of unique features.

With a water consumption of just 1 litre the **PREMAX FP** is guaranteed to be the most economical undercounter dishwasher on the market.

Only HOBART gives you a dishwasher that emits no steam when you open the door.

HOBART intelligent dishwashers detect the level of dirt and adjust the volume of water and rinse aid automatically in the current programme.

With the HOBART double rack system you can easily double your wash capacity and save up to 50% on operating costs.

Only HOBART has all the key functions of a dishwasher integrated in a single button. Additional information is available on a display that is activated by a proximity sensor. Operation is intuitive and easy for anyone to follow.

With our extensive range of models we offer the perfect solution for your requirements.



HOBART

PREMAX

360s Intensive w ↑
Continuous
360s Cutlery ↓

HOBART

OUR MODELS



PREMAX FP

With a water consumption of just 1.0 l it is the most economical undercounter dishwasher on the market and also the only undercounter dishwasher that can use hot steam to manage extreme levels of dirt.



PROFI FX

The **PROFI** model for reliable and simple washing of tableware, cutlery and glasses. Ideally suited for use in restaurants, bistros and cafés.



PROFI FXL

The **PROFI** model with the XL depth of the chamber cleans baking trays and meat trays with no trouble. This makes it the ideal partner for bakers, butchers and fast food outlets.

See our feature overview for more details.



ECONOMY

PREMAX LINE EXCLUSIVE

ECO VAPO RINSE

The primary task of rinsing is to remove detergent from the wash item. The patent pending switchable steam rinse cycle ECO vapo rinse of the **PREMAX**-line works in two phases. In the first phase, the detergent is rinsed off with water. The following ECO vapo rinse fills the wash chamber completely with steam which forms a microscopically thin film on the wash items and removes residual alkalinity. The self-drying effect of the wash items is additionally enhanced by the increased temperature penetration into the wash items. The steam rinse cycle ECO vapo rinse reduces the consumption of fresh water to 1 litre per cycle. Compared to standard machines, this represents a saving of 60 % in water, detergent and rinse aid.

SENSO-ACTIVE RESOURCE MANAGEMENT

The level of soil in the wash water depends on the daily changing menu, the dishes selected by guests and the time of day. Conventional machines do not adapt their cycles according to the level of soil in the machine. Usually they use the maximum amount of rinse water to ensure sufficient regeneration of the wash water. As a result they use more water than they actually need. The intelligent **SENSO-ACTIVE** resource management constantly measures the quality of the wash water and keeps the amount of rinsing needed in each rinse cycle to the minimum in order to guarantee a fully hygienic wash result. This reduces the amount of fresh water used per rinse cycle by up to 1,0 l. The intelligent **SENSO-ACTIVE** resource management can save up to 60 % water, detergent and energy.

DOUBLE RACK SYSTEM

Hotels, cafés and bistros with a high turnover of breakfast and coffee tableware often wash racks that only contain coffee cups. This means that the wash chamber does not run at full capacity. With the **HOBART** intelligent double rack system two racks can be washed in a single wash cycle. One rack of cups is washed underneath, in order to utilise the full power of the bottom wash arm, while a second rack containing dishes and cutlery can also be washed above it. The upper rack is loaded onto a mid-level rack guide and utilises the full power of the top wash arm. Thanks to the optimum use of the entire wash chamber it is possible to reduce the consumption of water, energy and chemicals by 50 % compared to conventional usage.



ACCURINSE RINSE PUMP

Ensuring constant temperature and volume of clean rinse water is vital to achieve not only clean, but hygienically clean tableware. The **ACCURINSE** rinse pump continuously distributes a constant amount of fresh water over the wash ware. The water volume is totally independent of flow pressure on site thus preventing any mixing with incoming cold water. The rinse pump saves water, energy and detergent.

WASH RESULT

PREMAX LINE EXCLUSIVE

HOT-TEMP WASHING

The washing is the result of a combination of temperature, mechanical action and chemistry. The water temperature has the biggest influence on the wash result – significantly more than wash pressure. In conventional dishwashers the wash temperature is at approx. 60 °C, but with the HOT-TEMP Washing of the **PREMAX**-line, the wash ware is washed at approx. 63 °C. This improves the efficiency of the detergent – the wash ware is cleaned faster whilst the capacity of the machine is raised by up to 45 racks/h.

CUTLERY CYCLE

Shining cutlery is a restaurant's signature. Food residues are extremely difficult to remove after a prolonged period - especially from the cutlery. Usually, you will need to soak the items by hand or wash them again to achieve a spotless result. HOBART's cutlery cycle in the **PREMAX**-line removes even persistent residues using steam. The wash cycle then washes the residues away. There is no need to pre-soak the items.



PERFECT DRYING MANAGER

The self-drying of the wash ware is highly influenced by its temperature and the moisture in the chamber of the machine. The PERFECT drying manager of the **PREMAX**-line has a multi-stage ventilation which extracts the air, saturated with moisture, out of the machine. Fresh air streaming in also absorbs moisture. The system of air diverters optimises the air circulation and enables a faster and even drying result. At the same time the temperature of the wash ware is reduced – especially glasses can soon be used again. The drying phase can be interrupted at any time. The input of humidity into the room decreases by 45 % compared to ordinary machines.

PERMANENT WASH PROGRAMME

The permanent wash programme is built-in as standard and can be adapted anytime to heavily soiled wash ware. No need to run a second cycle, only the wash phase is extended. No additional detergent dosing or rinsing is necessary. Time is saved and operation costs are reduced.



WASH RESULT

STARCH-REMOVAL CLEANING CYCLE

Depending on the type of food, and processes during meal service starch deposits will appear on the ware over time. The patent pending starch-removal cleaning cycle removes the starch from the crockery. Inconvenient and time consuming manual handling using aggressive detergents is eliminated. The starch-removal cleaning cycle assists the staff and guarantees shining crockery.

GENIUS-X² FINE FILTER SYSTEM

Permanently clean wash water is the key requirement for an optimal wash result with less detergent and water consumption. In the next generation of the GENIUS-X² fine filter system, the wash water is continuously put through a system of filters. During the wash cycle the majority of soil particles are removed during the first phase of draining. Any remaining soil particles are retained in the filter and are then removed during the second stage of draining, just before the final rinse. The tank water is then replenished with fresh hot rinse water. This optimal regeneration ensures a perfect wash result. The fine filter system cleans itself during the draining phase. GENIUS-X² helps to reduce detergent consumption considerably.



OSMOSIS IN DRAWER FORMAT

Water with a high mineral content leaves an unattractive residue on knives, forks and plates as it dries and this must then be polished away by hand, resulting in more work and implications in terms of hygiene. The optional HYDROLINE PURE RO-I reverse osmosis process removes the minerals that cause this residue and supplies the dishwasher with purified water. Cutlery and plates emerge from the machine sparkling clean and manual polishing becomes a thing of the past. The modular drawer construction means the RO-I can be used with all dishwashers as an integrated substructure or positioned vertically on one side. The HYDROLINE PURE RO-I reverse osmosis process offers spotless wash results along with versatile, space-saving installation options.



AQUA-NEW X-CHANGE CYCLE

Items like milk glasses, cappuccino cups, ice cream bowls and greasy utensils overload the wash water with fat, reducing the detergent efficiency. HOBART's unique AQUA-NEW X-change cycle drains the wash water from the tank before the rinse, pumping out emulsified fat and other food soil. The tank is then refilled with fresh water from the rinse for the following cycle. The X-change cycle can be activated automatically as required at the touch of a button.

WIDE ANGLE NOZZLE FAN

Wash efficiency largely depends on the distribution of the wash water and on avoiding any masked areas. Spraying angles and the precision of the wash jets are vital factors in achieving a powerful, searching wash action and the patented wide angle nozzles FAN provide a substantially broader and more precise spray pattern. Compared with conventional wash arm systems the wash water is distributed more efficiently, masking is avoided and the wash result, especially in the corners, is considerably improved.



INTERLOCKED STRAINER

Clean wash water and accurate detergent dosage are key factors in achieving a clean and hygienic wash result. An efficient filter system is useless if it is not in the right position. The strainer has an interlock which is continuously monitored by the control. The wash cycle can only be activated if the filter is correctly positioned.





HANDLING

VAPOSTOP DOOR SYSTEM

When opening a conventional dishwasher hot steam escapes from the machine. The VAPOSTOP door system of the **PREMAX**-line extracts the moisture saturated air by means of a multistage ventilation. Due to the exhaust the escape of steam is effectively avoided. So removing the wash ware is much easier for the personnel and the guests at the bar are not disturbed by escaping steam. The input of humidity into the room decreases by 45 % compared to ordinary machines.

VISIOTRONIC CONTROL

A control panel must show the operator key information, such as the programme status or warning signals, immediately and at a glance. Further information about the current wash programme, temperature or operating data must be accessible quickly and easily. The intelligent VISIOTRONIC control panel satisfies all these requirements. All the necessary information appears in the large display, both in clear text and in the form of symbols. The display is activated by a proximity sensor and is deactivated when the operator moves away from the machine. The START button is permanently lit up and uses colour coding to show the current operating status of the machine. The intelligent VISIOTRONIC control panel ensures a simple and intuitive operating of the HOBART dishwashers.



REMAINING TIME INDICATOR

The remaining time indicator visibly shows the progress of the running wash programme. The four segments of the START button colour up clockwise in sequence. Even in peak times personnel can set their priorities at a glance and work more efficiently. The PERFECT drying manager also shows the remaining time in the display.

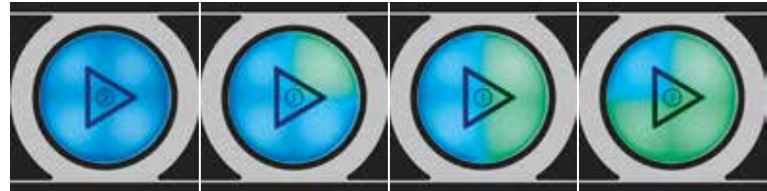

HYGIENE PROGRAMME

A dirty dishwasher cannot deliver clean results and over a period of time soil particles, starch and sometimes limescale can build up inside the machine leading to bacteria and poor machine hygiene. Together with the specially formulated chemical tablets HOBART's hygiene programme effectively removes these deposits from the wash tank and chamber leaving a clean machine with a fresh smell.



CLIP-IN WASH AND RINSE ARMS

To make the machine cleaning even easier both the wash and rinse arms can be lifted out of the wash chamber using the CLIP-IN system with one hand. After cleaning, the wash and rinse arms can be replaced just as easily with no tools required.

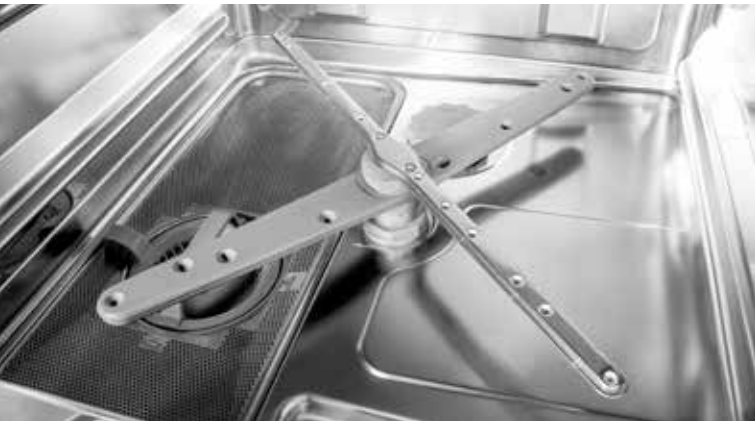

INTEGRATED WATER SOFTENER

Limescale is a mineral that is responsible for building up of deposits on machine parts, in the boiler and on heating elements reducing efficiency and detergent performance, increasing running costs and causing failures. Dishwashers can be equipped with an integrated water softener. The automatic water softening process ensures the smooth operation of the dishwasher. It also provides effective protection for the machine - and in particular for the heating elements in the boiler – from building up of limescale.



SOFT START PROTECTION

In bars and bistros glass or dishwashers are often installed under the counter, close to guests. The soft start protection considerably reduces the noise emission. In addition it avoids shaking up glasses and ware, and protects components in the long run.

INTEGRATED CHEMICAL CONTAINERS

Large liquid containers for rinse aid and detergent can be retrofitted to reduce the refill frequency and free up space near the machine. The large container openings make it easy to refill the containers without spillage in the course of a busy day. The fill level indicator shows on the display when it is time to refill detergent and rinse aid to ensure optimum wash results.

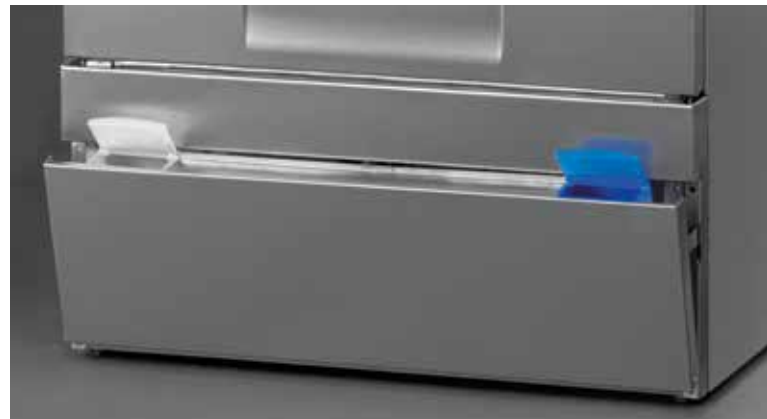

FILL LEVEL INDICATOR

The integrated fill level indicator monitors the contents of external as well as integrated chemical canisters and indicates when it is time to refill detergent and rinse aid. This ensures effective long-term wash results.

HOBART



RELIABILITY & FLEXIBILITY

XL WASH CHAMBER

In bakeries, besides coffee dishes also presentation trays and baking trays are washed. In butcheries and the meat processing industry additionally EN-boxes and large sheets have to be washed. Due to an enlarged chamber the **PROFI FXL** model offers space for wash ware up to 600 x 400 mm.



GARANT QUALITY MANAGEMENT

A commercial dishwasher is used up to 85,000 times during its lifecycle. The HOBART reliability is no coincidence: therefore, our machines are repeatedly exposed to daily requirements, in order to guarantee performance after progressive use. For example the door is opened and shut more than 100,000 times.

DRAIN PUMP

The drain pump, a standard fitting, drains the waste water into any outlet with a maximum height of 1 m.

MULTI-PHASING (230/400 V)

Multi-Phasing allows the operation of the same machine either on 230 V or 400 V. According to the local situation the phasing can be changed by simple plugging, possible at any time.

SMOOTH COUNTERBALANCED DOOR

Hydraulic shock absorbers give the spring loaded door a gentle opening and a silent closing. The flat rack slides on the inner door make loading and unloading easy from all sides.



HOBART

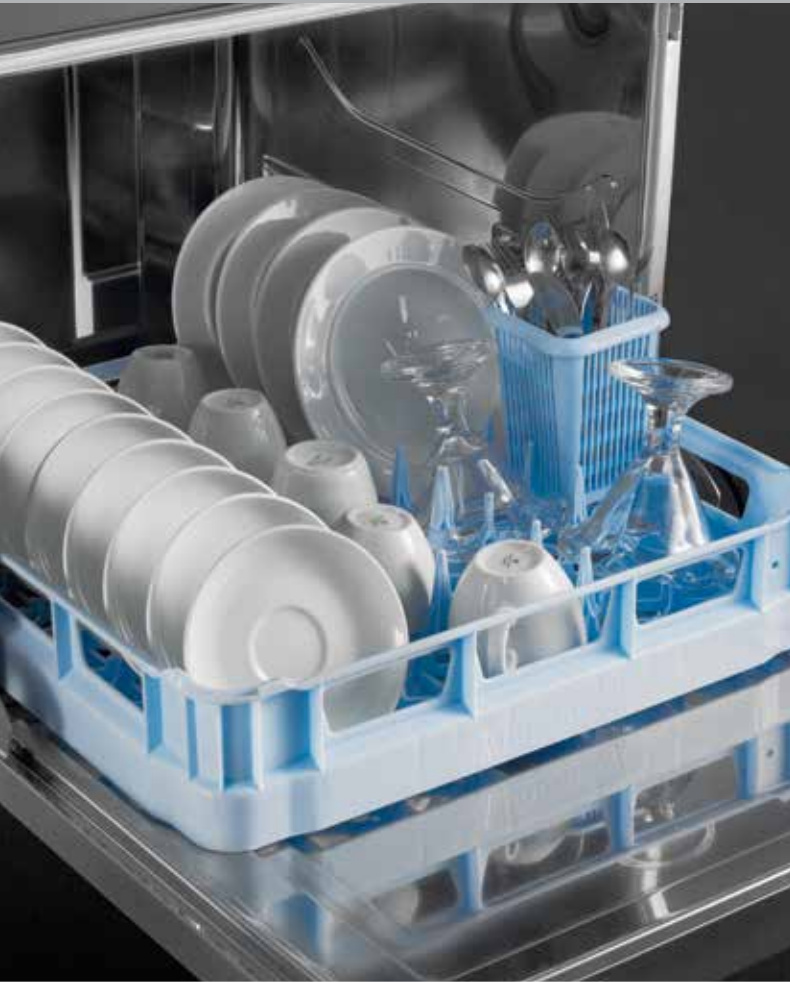

DRAWINGS

FP | FX

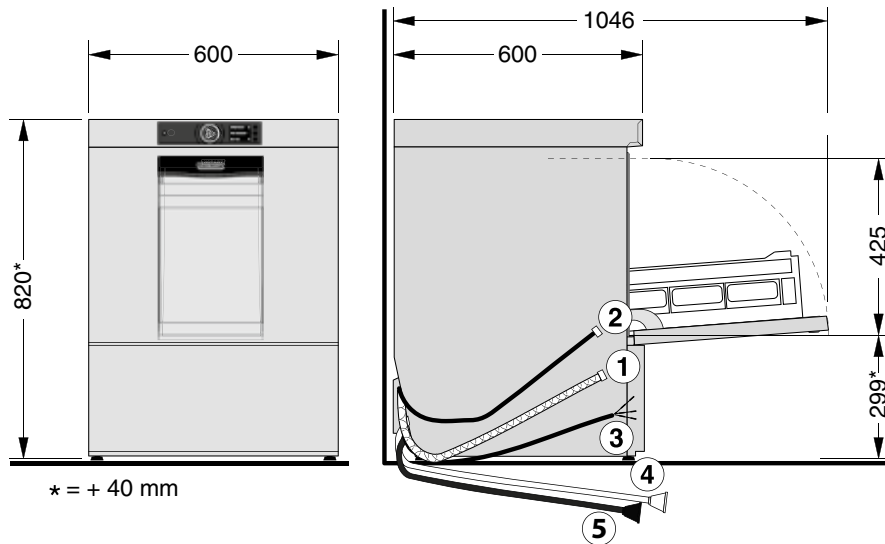

FXL

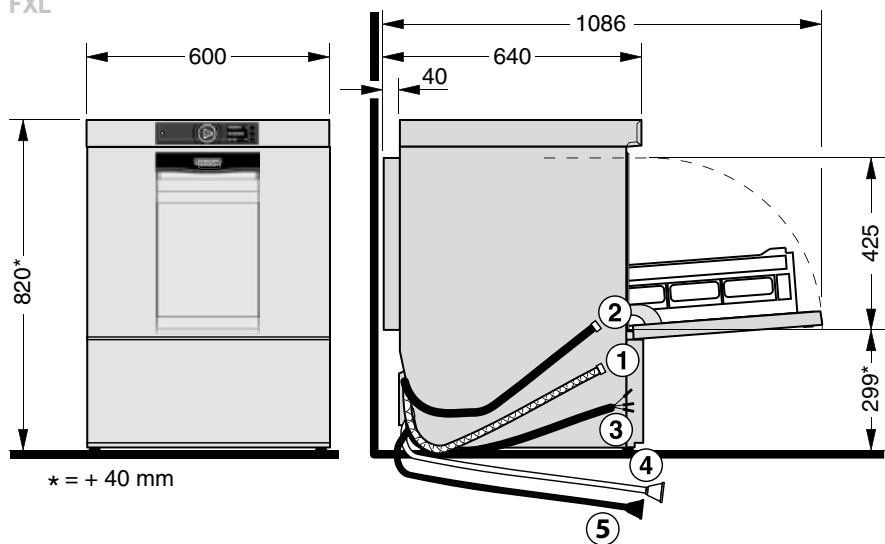

- ① flexible drain hose ② fresh-water connection ③ power cord ④ hose for detergent ^{a)} ⑤ hose for rinse aid ^{a)}
^{a)} for machines with external containers



FEATURES

MODEL	PROFI-LINE		PREMAX-LINE
	FX	FXL	FP
ECONOMY			
ECO vapo rinse	–	–	● PREMAX-LINE EXCLUSIVE
SENSO-ACTIVE resource management	●	●	●
Double rack system	○	○	○
ACCURINSE rinse pump	●	●	●
WASH RESULT			
HOT-TEMP washing	–	–	● PREMAX-LINE EXCLUSIVE
Cutlery cycle	–	–	● PREMAX-LINE EXCLUSIVE
PERFECT drying manager	–	–	● PREMAX-LINE EXCLUSIVE
Permanent wash programme	●	●	●
Starch-removal cleaning cycle	●	●	●
GENIUS-X ² fine filter system	●	●	●
Osmosis in drawer format	○	○	○
AQUA-NEW X-change cycle	●	●	●
Wide angle nozzle FAN	●	●	●
Interlocked strainer	●	●	●
HANDLING			
VAPOSTOP door system	–	–	● PREMAX-LINE EXCLUSIVE
VISIOTRONIC control	●	●	●
Remaining time indicator	●	●	●
Hygiene programme	●	●	●
CLIP-IN wash and rinse arms	●	●	●
Integrated water softener	○	○	○
Soft start protection	●	●	●
Integrated chemical containers	○	○	○
Fill level indicator	●	●	●
RELIABILITY & FLEXIBILITY			
XL wash chamber	–	●	–
Smooth counterbalanced door	●	●	●
Guaranteed Quality Management	●	●	●
Drain pump	●	●	●
Multi-Phasing (230/400 V)	●	●	●

● Inclusive ○ Optional – Not available

TECHNICAL DATA

MODEL	PROFI-LINE		PREMAX-LINE
	FX	FXL	FP
CYCLE TIMES*	90 / 180 / 360 sec. and special cycles	90 / 180 / 360 sec. and special cycles	80 / 150 / 170 sec. and special cycles
CAPACITY			
Racks	40 /h	40 /h	45 / 21 /h**
Dishes	720 /h	720 /h	810 / 378 /h**
Glasses	1.440 /h	1.440 /h	1.620 / 756 /h**
TANK CAPACITY	10.6 l	10.6 l	10.6 l
WATER CONSUMPTION	2 l/rack	2 l/rack	1.0 l/rack**
WASH PUMP	0.6 kW 350 l/min	0.6 kW 350 l/min	0.6 kW 350 l/min
Tank heating	0.8 kW	0.8 kW	0.8 kW
BOOSTER LOADING			
Standard	6.2 kW	6.2 kW	6.2 kW
Alternative	2.0 kW	2.0 kW	2.0 kW
TOTAL LOADING			
Standard	7.7 kW 3 x 16 A	7.7 kW 3 x 16 A	7.7 kW 3 x 16 A
Alternative	3.6 kW 16 A	3.6 kW 16 A	3.6 kW 16 A
Power supply	400 / 50 / 3N (230 / 50 / 1)	400 / 50 / 3N (230 / 50 / 1)	400 / 50 / 3N (230 / 50 / 1)
DIMENSIONS			
Width	600 mm	600 mm	600 mm
Depth	600 mm	600 mm	600 mm
Height	820 mm	820 mm	820 mm
Loading height	425 mm	425 mm	425 mm
Rack size	500 x 500 500 x 530 mm	500 x 500 500 x 530 mm	500 x 500 500 x 530 mm

Multi-Phasing allows the operation of the same machine either on 230 V or 400 V. The change is done by simple plugging on site when installing the machine.

* The machine is equipped with an automatic cycle-time control which ensures hygienic rinse temperatures even on a cold-water supply or with reduced heating performance.

** For use with the ECO Vapo Rinse

CONCEPT SOLUTIONS FOR OPTIMISED WASHING RESULTS

WATER TREATMENT

The right solution for every water quality: The partial and total desalination cartridges HYDROLINE STAR and STAR EXTRA and the HYDROLINE PURE RO-I and RO-C reverse osmosis systems guarantee spotless wash results with no additional polishing required.

WASHING CHEMICALS

The right detergent for every application – perfectly suited to the individual machine. **The HYLINE hygienic range.**





THE COMPANY

HOBART is the world market leader in commercial warewashing technology and renowned manufacturer of cooking, food preparation, refrigeration, and environmental technology. Established 1897 in Troy, Ohio, HOBART today employs more than 6,900 employees around the world. At our manufacturing plant in Offenburg, Germany, HOBART develops, produces, and distributes warewashing technology worldwide. Internationally, gastronomy hotels canteens, bakeries and butcher shops, supermarkets, airlines and cruise ships swear by our innovative products, which are considered to be economical and ecological market leaders.



WHENEVER THE FIRST
MACHINE WILL BE CAPABLE OF
WASHING WITHOUT WATER –
IT WILL BE A HOBART.

We provide this promise of quality to our customers,
and it represents our personal standard upheld
by all our staff at HOBART.

OUR VISION - WASH WITHOUT WATER

Intensive market research has shown, that our customers expect warewashing technology that combines efficiency with optimal performance. We hold ourselves to these claims, and they form the foundation for our vision of „washing without water“. This vision is our continuous incentive to walk on new paths in order to constantly reduce the water, energy and chemical consumption. Step by step, we would like to come closer to our goal with innovative excellence, and we already know: Whenever the first machine will be capable of washing without water – it will be a HOBART.

OUR FOCUS

INNOVATIVE - ECONOMICAL - ECOLOGICAL

This is our philosophy. To us, innovation means continuously setting new standards in technology, combined with real added value for the customer. An enterpriseowned technological centre and an innovation centre for warewashing technology at our headquarters in Germany make this possible. Highly efficient products are created with bundled innovation, which continuously confirm our status as technological leader. To be economical means to set standards in relation to the lowest operating costs and minimal use of resources, and to revolutionise the market continuously. To be ecological means a responsible handling of resources and a sustainable energy policy. This applies not only to the product in use, but in general to all areas of the organisation, such as purchasing or manufacturing.



2

**DEUTSCHLAND/ÖSTERREICH****HOBART GMBH**

Robert-Bosch-Straße 17 | 77656 Offenburg
Tel.: +49(0)781.600-0 | Fax: +49(0)781.600-23 19
info@hobart.de | www.hobart.de

 Werkskundendienst 0180.345 62 58
Zentraler Verkauf 0180.300 00 68

SCHWEIZ**GEHRIG GROUP AG**

Bäulerwisenstrasse 1 | 8152 Glattbrugg
Tel.: +41(0)43.211 56-56
Fax: +41(0)43.211 56-99
info@gehriggroup.ch
www.gehriggroup.ch

FRANCE**COMPAGNIE HOBART**

ZI PARIS EST - Allée du 1er Mai - B.P. 68
77312 MARNE LA VALLEE Cedex 2
Téléphone: +33(0)1 64 11 60 00
Fax: +33(0)1 64 11 60 01
contact@hobart.fr
www.hobart.fr

UNITED KINGDOM**HOBART UK**

Southgate Way | Orton Southgate
Peterborough | PE2 6GN
Phone: +44(0)844 888 7777
customer.support@hobartuk.com
www.hobartuk.com

BELGIUM**HOBART FOSTER BELGIUM**

Industriestraat 6 | 1910 Kampenhout
Phone: +32(0)16 60 60 40
Fax: +32(0)16 60 58 99
sales@hobart.be
www.hobart.be

NEDERLAND**HOBART NEDERLAND B.V.**

Pompmolenlaan 12 | 3447GK Woerden
Tel.: +31(0)348.46 26 26
Fax: +31(0)348-43 01 17
info@hobartnederland.nl
www.hobartnederland.nl

NORGE**HOBART NORGE**

Gamle Drammensvei 120 | 1363 HØVIK
Tel.: +47(0)67 10 98 00
post@hobart.no
www.hobart.no

SVERIGE**HOBART SCANDINAVIA APS**

Box 2101 | 196 02 Kungsängen
Tel.: +46(0)8 584 50 920
Fax: +46(0)8 584 50 929
info@hobart.se
www.hobart.se

DANMARK**HOBART SCANDINAVIA APS**

Håndværkerbyen 27 | 2670 Greve
Tel.: +45(0)43 90 50 12
Fax: +45(0)43 90 50 02
post@hobart.dk
www.hobart.dk

AUSTRALIA**HOBART FOOD EQUIPMENT**

Unit 1 / 2 Picken Street | Silverwater NSW | 2128
Tel.: +61(0)2 9714 0200
Fax: +61(0)2 9714 0242
www.hobartfood.com.au

KOREA**HOBART KOREA LLC**

7th Floor | Woosan Bldg | 108 | Bangi-dong
Songpa-gu | Seoul 138-050
Phone: +82(0)2 34 43 69 01
Fax: +82(0)2 34 43 69 05
contact@hobart.co.kr
www.hobart.co.kr

JAPAN**HOBART (JAPAN) K.K.**

Suzunaka Building Omori
6-16-16 Minami-Oi | Shinagawa-ku | Tokyo 140-0013
Phone: +81(0)3 5767 8670
Fax: +81(0)3 5767 8675
info@hobart.co.jp
www.hobart.co.jp

SINGAPORE**HOBART INTERNATIONAL (S) PTE LTD**

158 | Kallang Way | #06-03/05
Singapore 349245
Phone: +65(0)6846 7117
Fax: +65(0)6846 0991
enquiry@hobart.com.sg
www.hobart.com.sg

THAILAND**HOBART (THAILAND)**

889 Thai CC building | 31st Floor | Room no. 311
South Sathorn Rd. | Yannawa | Sathorn
Bangkok 10120
Phone: +66(0)2-675-6279 | Fax: +66(0)2-675-6280
enquiry@hobartthailand.com | www.hobartthailand.com

OTHER COUNTRIES**HOBART GMBH**

Robert-Bosch-Straße 17 | 77656 Offenburg | Germany
Phone: +49(0)781.600-28 20
Fax: +49(0)781.600-28 19
info-export@hobart.de
www.hobart-export.com

Die Angaben in diesem Prospekt beruhen auf dem Stand 06/2014. Technische Änderungen oder Änderungen der Ausführung bleiben vorbehalten

The details given in this brochure are correct as of 06/2014. We reserve the right to technical or design modifications

Document non contractuel. Les indications de ce prospectus sont conformes à la mise à jour de 06/2014. Nous nous réservons le droit de modifier les données ou les configurations techniques de nos machines.

